

APPLICATION		REVISIONS			
NEXT ASSY.	USED ON	REV.	DESCRIPTION	DATE	APPROVED
		2	CHANGED DESCRIPTION NUMBERS	4-1-15	HG
		3	CORRECTED PART NUMBERS	4-11-16	HG
		4	REDRAWN WITH REDESIGNED PARTS	5-19-16	

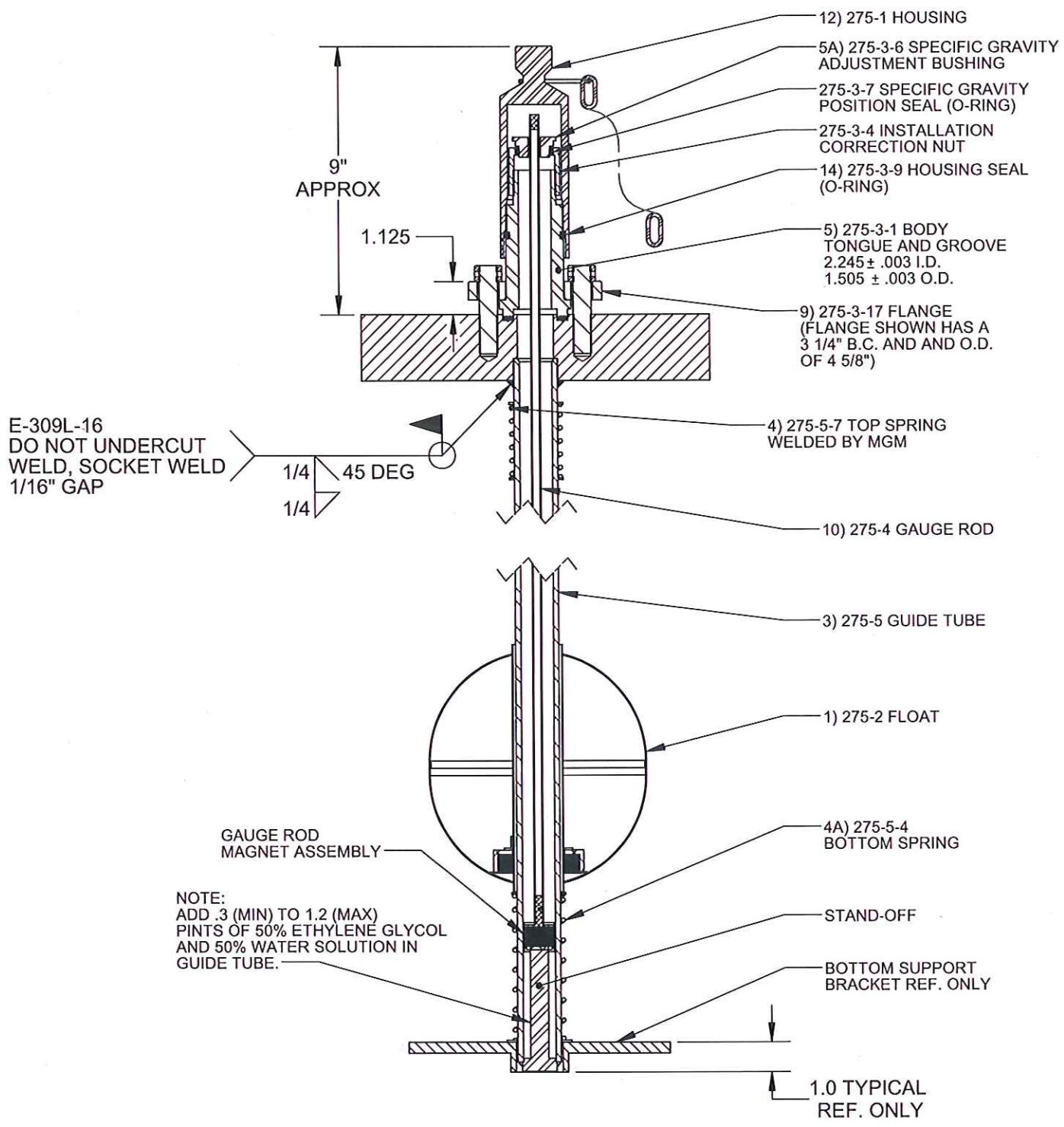

E-309L-16
DO NOT UNDERCUT
WELD, SOCKET WELD
1/16" GAP

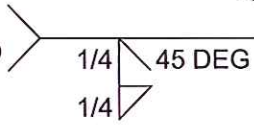

NOTE:
ADD .3 (MIN) TO 1.2 (MAX)
PINTS OF 50% ETHYLENE GLYCOL
AND 50% WATER SOLUTION IN
GUIDE TUBE.

CONTRACT NO.

MGM METAL GOODS MANUFACTURING
428 W. 8TH STREET
BARTLESVILLE, OK. 74003

UNLESS OTHERWISE SPECIFIED
DIMENSIONS ARE IN INCHES.
TOLERANCES ARE:
FRACTIONS DECIMALS ANGLES
±.015 .XX ±.015 ±1°
.XXX ±.005

APPROVALS	DATE
DRAWN S.PIERCE	5-19-16
CHECKED <i>JG</i>	7-29-16

TITLE
275 MAGNETIC GAUGING DEVICE

MATERIAL
FINISH

ENGR.
ISSUED

SIZE	PART NO.	DWG. NO.	REV.
A	275A	275	4

DO NOT SCALE DRAWING

SCALE	WEIGHT	SHEET
1:5		2B